

# IPX7

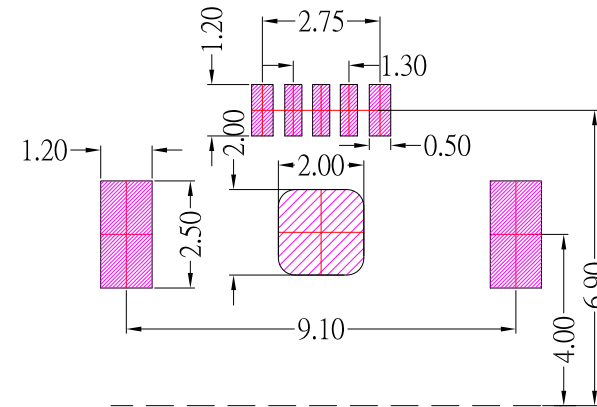
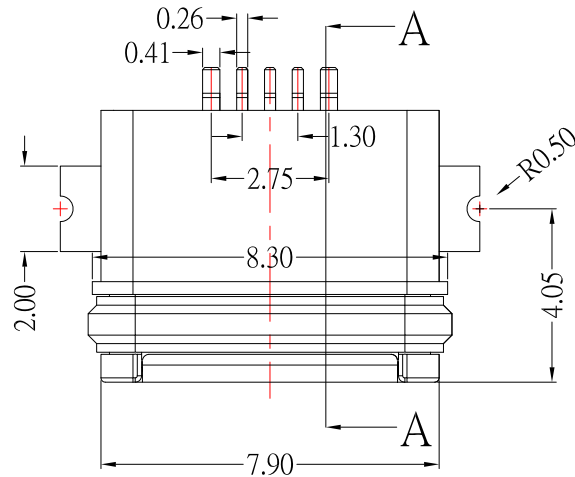

P.C.B LAYOUT MOUNTING PATTERN

NOTES:

MATERIAL:

- 1.1 HOUSING: HIGH TEMPERATURE
- 1.2 CONTACT: COPPER ALLOY
- 1.3 SHELL: SUS

FINISH:

- 2.1 CONTACT: PLATED GOLD IN MATING AREA ;  
GOLD PLATED ON SOLDER BALLS ;  
NICKEL UNDER PLATED OVERALL
- 2.2 SHELL: NICKEL UNDER PLATED SURFACE LAYER

3.SPECIFICATION:

- 3.1 RATING: 1.8A(PIN1&5) , 1.0A(PIN2&3&4)
- 3.2 DIELECTRIC WITHSTANDING VOLTAGE: 100 VAC
- 3.3 CONTACT RESISTANCE: 30 mΩ MAX.
- 3.4 INSULATION RESISTANCE: 1000 MΩ MIN.
- 3.5 TEMPERATURE RANG: -30°C ~ 80°C

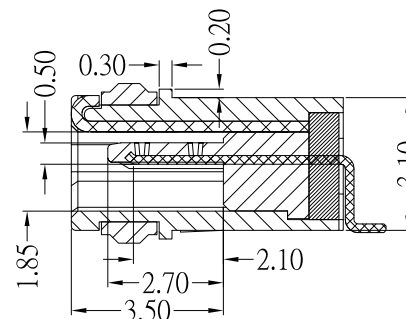
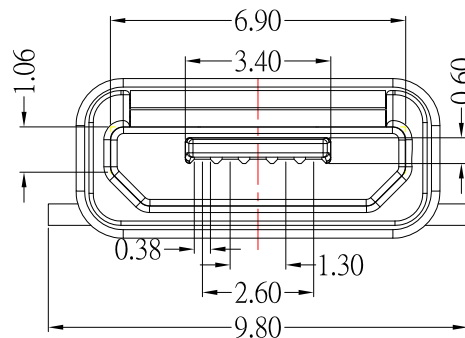
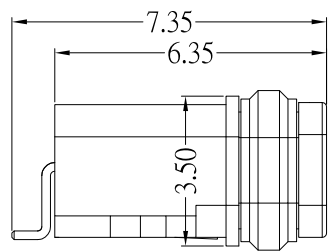

A-A

東莞市高迪電子有限公司  
DONG GUAN GAO DI ELECTRONICS CO., LTD

TOLERANCE UNLESS OTHERWISE STATED:  
Up to 5 ±0.2  
Above 5 ~ 15 ±0.3  
Above 15 ~ 30 ±0.4  
Above 30 ~ 50 ±0.5  
Angle ±0.3°

3RD. ANGEL'S

UNITS MM

DRAWN BY:	DATE	MAT'L	TITLE	CONNECTOR
Jack Lu	12/06/19		MODLE	MICRO USB 5PF B TYPE H 3.95 IPX7
CHECKED BY:	DATE	FINISH	DWG NO.	MRUSB-5B-WP16-S347
Jacky Chen	12/06/19	SCALE 1 : 1	PART NO.	MRUSB-5B-WP16-S347
APPROVED BY:	DATE	SHEET NO.	1 of 1	
Tony Kao	12/06/19			

ITEM NO.	DESCRIPTION	DRAWN	DATE